

NEWSLETTER 23: 12 August 2022

Reporting back to you

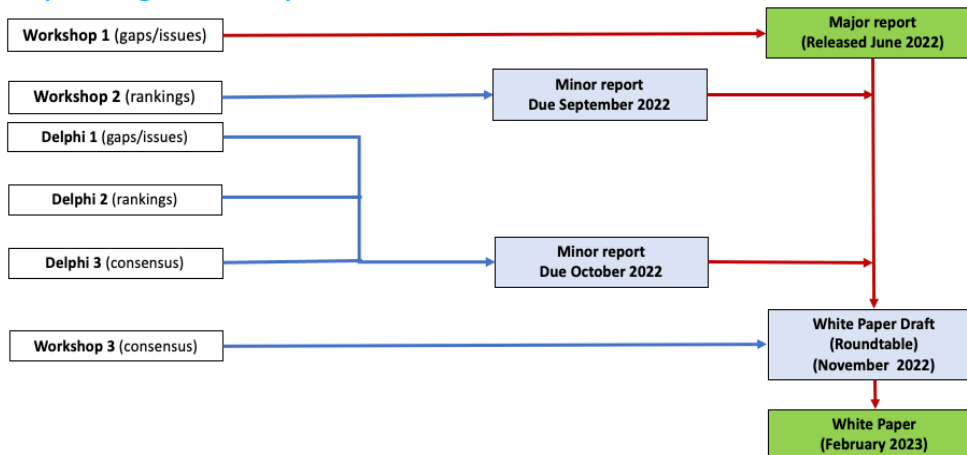

The major Workshop 1 report went live a few weeks ago. The Management Team are now finishing workshop 2 analysis. We will report on teams' ranking of research gaps through Regional Zooms (see below) and in a minor report. The Delphi study has survey 2 data collection currently underway. As the Delphi is a specific research approach, we will collate all results in one report to be shared once consensus is reached. The culmination of all findings, both Delphi and workshop data, will form the basis of the white paper, which will summarise similarities and differences of both and will provide strategic directions to be discussed through the roundtables.

Roundtables

We are pleased to confirm the following Copenhagen Roundtable details.

- **Mon 28th Nov, 3-4.30pm**, (optional) presentation by Morris and Imms.
- **Tues 29th Roundtable from 10am - 4.30pm**, followed by drinks.
- **Wednesday 30th, 9am – 10.30am** informal Plenary.

The Aus/NZ/SE Asia/Americas Roundtable information was listed in Newsletter 22

Regional Zooms – an informal brief on our progress

Europe (hosted by Wes); **Wed 7th September 9.00am** (London time)

- <https://unimelb.zoom.us/j/88042187895?pwd=UFlaNjQzNk9ONXB0SU5NQjJmVndkZz09> Passcode 969742

Americas (hosted by Julia); **Thursday 8th September 9am** (Dallas time)

- <https://unimelb.zoom.us/j/85331589571?pwd=cVoycXNwcTFtaUdScmpkVVVwQ2d6UT09> Password: 393284

Aust/SE Asia/NZ (hosted by Chris); **Mon 29th August, 5.30pm** (Auckland time)

- <https://unimelb.zoom.us/j/88121958378?pwd=TWpvVHd0R3YzU2YzSk01VWNLa1hvdz09> Passcode 103080

Team Mzansi South Africa

The Mzansi South Africa team is made up of a diverse group of people who have come together to contribute to the ILE+SE project over a common interest in improving the state of education in South Africa. The group includes representation from the fields of design & architecture, education innovation, academia, psychology, communication, manufacturing and providing services within informal settlements.

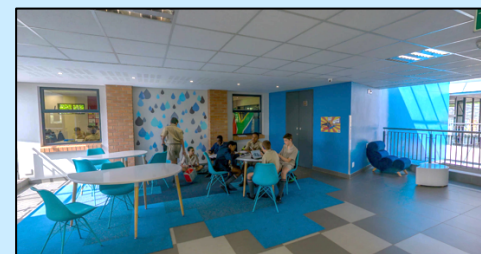

ILE's are not particularly common in South Africa, making the opportunity to learn from and connect with other contexts and ILE experts around the world so important. There is also a deep awareness that South Africa's education sector poses both unique challenges and opportunities which relate to the inherent diversity within South African society. Particularly the legacy of disadvantage and oppression from the Apartheid era, huge cost constraints and an extremely unequal spectrum of education facilities and education system. The intention is to use this project as a springboard for further initiatives and research into relevant topics within the education field in South Africa.

Upcoming Café Session

Hosted by Wes Imms

Have school designs 'peaked'? What's next?

August 22nd, 8pm Melbourne Time

See Newsletter 22 for Zoom link